

Agilent 34980A and L4445A Configuring an RF/Microwave Switch System

Application Note

34980A and
Plug-in Modules



L4400 Modules

Contents

Introduction	2
Overview of 34980A RF/Microwave Switch Modules	3
Overview of 34945A/L4445A RF/Microwave Switch/Attenuator Driver	5
Key RF/Microwave Test System Specifications	7
Tips in building an RF/Microwave Test System	9
Key factors in selecting RF/Microwave Switches	10
Controlling Agilent Switches/Attenuators	11
34945EXT Distribution Board Configuration	13
Custom Switching and the 34945A/L4445A Switch Driver	24
Example Switch Driver Configurations	26
The Web Server Diagnostic Tool	28
Switch Executive vs. Agilent Switch Sequencer	29
Conclusion	31



Agilent Technologies

Introduction

LAN (Ethernet) is fast becoming the basis for a new set of instrumentation called LXI, or LAN eXtensions for Instrumentation. LXI is a collection of standards that specify how instruments behave on LAN. The 34980A Switch/Measure Unit and the L4400 Modules are both LXI Class C compliant which means these instruments can be operated via LAN, follow a specified LAN protocol, and adhere to requirements such as a built-in Web Server, IVI software drivers, and others. Please refer to the Related Literature section at the end of this application note for more information about LXI and IVI software drivers.

The Agilent 34980A Multi-function Switch/Measure Unit provides the core switching functionality, stimulus/measurement capabilities, and performance necessary for low to medium-density switching/measurement applications from design verification to functional test. From relatively low frequency applications like automotive electrical component testing to higher frequency switching needs in aerospace/defense and wireless communications,

the 34980A becomes the heart of the test system – routing signals between the Device Under Test (DUT) and instrumentation through a wide range of switch modules, internal analog busses, providing internal DMM measurements, high-speed digital IO, totalize, and static/dynamic analog outputs. The 34980A comes standard with LAN, USB, and GPIB interfaces and also includes an easy to use Web Server, Front Panel, and driver software for all major software development platforms. These connectivity features give the flexibility to build and adapt widely varying test system configurations.

The 8-slot, 3 U high, full rack 34980A has more than 14 switch modules offering multiple switch topologies such as multiplexer, matrix, general purpose switches, and a variety of RF and microwave switch modules – from DC to 20 GHz. For applications that require discrete switches/attenuators located close to the DUT, the 34980A also provides the 34945A Switch Driver Module designed to directly drive Agilent's most popular switches and attenuators.

The L4400 Modules are 1 U, half rack instruments that encompass the benefits of small size, rack-mountable, and with remote capabilities. The L4400 is a family of stand-alone LXI modules created from key 34980A modules in the area of Low/High Frequency Switching, Digital I/O, Analog Outputs, and Counters. In particular, the L4445A was created as a stand-alone version of the 34945A Switch Driver. With its small size and LAN connectivity, this switch/attenuator driver can be placed wherever your application needs it.

Agilent Technologies has been providing custom RF/Microwave switch matrix solutions for many years. A test system specification for RF/Microwave switching is submitted, and the desired configuration is completely provided by Agilent. Agilent is in the unique position of supplying the highest quality RF/Microwave components, electronic control of those components, and the expertise to integrate those components into a high quality switch solution.

However, you may need to rapidly deploy custom RF/Microwave Switch solutions for your testing needs, so you need to be in control of lead times and costs associated with those switch solutions. In other words, you are a Do-It-Yourselfer.

This application note will focus mainly on helping the Do-It-Yourself engineer who needs to control discrete external switches/attenuators. You will learn how the 34945A/L4445A Switch Driver, in combination with Agilent's most popular switches and attenuators, provides the best off-the-shelf RF/Microwave Switch solution to speed your test system integration and to control costs.

Overview of 34980A RF/Microwave Modules

RF and Microwave switches find use in a wide variety of applications that range from 30 MHz to over 20 GHz:

- Wireless Communications
- Broadband CATV
- Communication Satellites
- Test and Measurement Equipment
- Electronic Radar and Defense Systems
- Avionics
- Medical Electronics
- Space Programs

High Frequency measurement systems can be configured to route RF/microwave signals in a variety of configurations:

- Selection from multiple signal sources to a single output
- Selection of multiple input signals to a single measurement instrument
- Transfer switching to insert or remove a device in a signal path
- Matrix switching of multiple inputs and outputs

For many test system applications, the 34980A's RF and Microwave modules provide the convenience, functionality, and performance needed to switch signals between the DUT and oscilloscopes, spectrum analyzers, network analyzers, and other test equipment. The modules are positioned in the 34980A's 8-slot mainframe, and flexible or semi-flexible coax cable is routed between the DUT fixture, mainframe switch modules, and test instruments. The 34980A provides four RF and Microwave modules:

- 34941A – Quad 1x4, SMA, DC to 3 GHz, 50 ohm unterminated
- 34942A – Quad 1x4, mini SMB, DC to 1.5 GHz, 75 ohm unterminated
- 34946A – 2 SPDT, SMA, DC to 4 GHz (or 20 GHz), 50 ohm terminated
- 34947A – 3 SPDT, SMA, DC to 4 GHz (or 20 GHz), unterminated

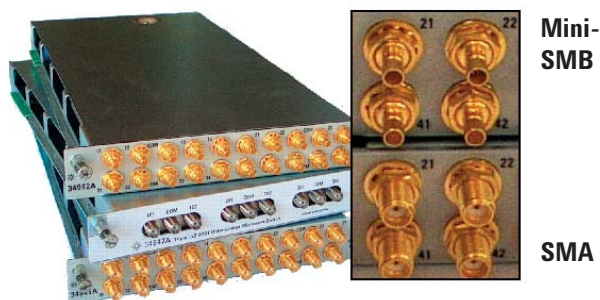

Using RF and Microwave Modules

Using 34980A mainframe modules to construct your high frequency test system has the following attributes:

Benefits:

- Convenient – no special hardware mounting
- Easy re-configuration using flexible cables
- Easy to add switches by adding switch modules
- Easy to replace switches by replacing switch modules

Limitations:

- Longer signal paths between DUT and instruments
- Higher insertion loss with longer, flexible cables
- Low-loss flexible cables are very expensive
- Signal phase is harder to control between multiple paths

Using Discrete Switches and Attenuators

In many applications, it is critical to locate the switching as close as possible to the DUT. Discrete switches, attenuators, couplers, filters, etc. can be mounted near or within the test fixture. These discrete devices can be controlled by a Digital Output Module, but a better solution is to use a Switch/Attenuator Driver that is specifically designed to provide all of the following features:

- Digital Outputs to drive relay coils in either pulsed or constant voltage mode
- Digital Outputs that can drive LEDs used in control panels
- Digital Inputs to sense the position of the switches
- Power distribution between the power supply, switches, and control logic
- Report generation that indicates how often switches have been actuated

The 34980A provides the 34945A Switch Driver module to control discrete RF/Microwave switches and attenuators external to the 34980A mainframe. The L4445A is the LXI Module version of the 34945A. Both these products provide all of the above features and extend the switching capacity to hundreds of RF/microwave switches at frequencies over 20 GHz.

Using discrete switches and attenuators to construct your high frequency test system has the following attributes:

- Specific frequency range components can be selected
- High performance Semi-rigid or Hand-conformable coax cabling can be used
- Switches can be mounted within the test fixture of the DUT
- All high frequency signal routing can be contained within a shielded box
- Shorter cables reduce insertion loss and increase signal integrity
- Exact length signal paths are now possible to control phase of signals

Overview of 34945A/L4445A RF/Microwave/Attenuator Driver

The 34945A/L4445A Microwave Switch/Attenuator driver is designed to support virtually any RF/Microwave switch or attenuator. The two products make it especially easy to control and monitor Agilent's most popular RF/Microwave switches and attenuators. Agilent provides a wide range of discrete RF/Microwave switches and attenuators that meet very high standards of performance: High Isolation, High Repeatability, Low VSWR, Low Insertion Loss, and Very Long Life.

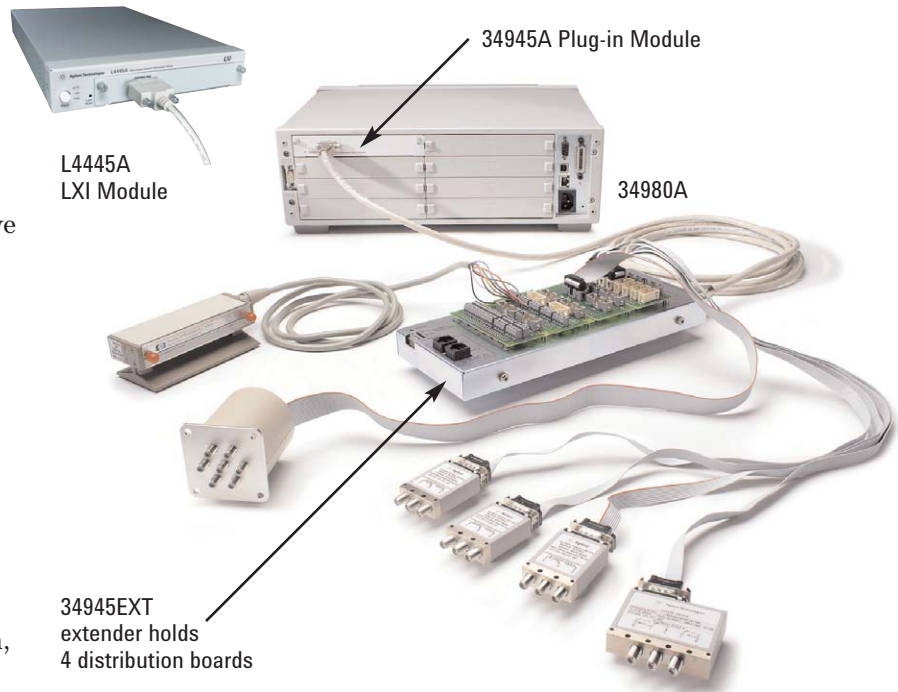

The RF/Microwave Switch/Attenuator Driver

Each **L4445A** or **34945A** **plug-in module** connects to a **34945EXT** **extender module** through a standard 9-pin D-sub datacomm cable. Each 34945EXT extender module uses up to four 34945EXT distribution boards (**Y1150A-Y1155A**) for connecting directly to external switches. Up to seven more 34945EXT extender modules can be daisy-chained (from one 34945EXT to the next) using a standard RJ-45 cable.

The 34945A/L4445A *can* **supply 24 V power to the first 34945EXT** through the 9-pin D-sub cable. This allows driving common 24 V RF/Microwave switches and attenuators directly without the need for an external

power supply. Each daisy-chained 34945EXT extender module requires power from an external power supply. A total of eight 34945EXT extender modules are supported in a single 34980A mainframe. This can be a single

34945A and eight 34945EXT extenders, or it could be eight 34945As each with a single 34945EXT. You can also build any combination in between. The example below shows the use of the 34980A and the L4445A.

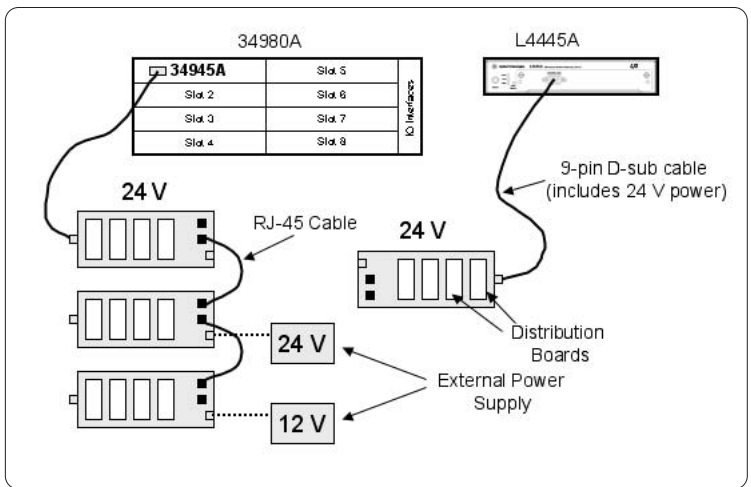

The previous figure shows some key aspects of the 34945A/L4445A Switch Driver:

- Each 34945A/L4445A module **can** supply 24 V to the **first** 34945EXT
- Daisy chained 34945EXT's **must** use an external power supply
- Each 34945EXT can only support one voltage type (24 V, 12 V, or 5 V)
- A total of eight (8) 34945EXT's can be present in a single 34980A mainframe or connected to an L4445A Module
- The 34945EXT's can be daisy chained or directly connected to 34945A/L4445A modules

There are five **distribution boards (Y1150A through Y1154A)** for directly driving Agilent's most popular switches using common ribbon cables and socket headers/connectors. The sixth distribution board, the **Y1155A**, is designed to drive virtually any switch or attenuator. Instead of providing socket headers to the switches, the Y1155A provides screw terminals to connect to relay coils and position indicators.

As seen in the diagram below, up to four (4) distribution boards can be mounted onto a single 34945EXT. The Y115x distribution boards are passive; they

only provide various socket headers or screw terminals that interface external devices to the 34945EXT.

The 34945EXT distribution boards provide position feedback and can directly drive LED's to be used to describe signal paths on a test system panel. It is particularly useful for test system operators to have a visual representation of the signal path.

The 34945EXT module is essentially a multifunction module:

- Digital outputs to drive relay coils (programmable pulse or continuous)
- Digital inputs to read position of switch contacts
- Digital outputs to drive LED's used for position indication
- Power distribution and current limitation (no fuses)

Each Y115x distribution board can drive up to 16 coils. The distribution boards can drive coils continuously or with programmable-width pulses. Continuous drive switches typically require a significant amount of current to energize a coil (100 mA to 300 mA each for 24 V coils, and much higher for 12 V and 5 V). Continuous drive switches usually have a single coil that closes a normally open switch. The switch is closed for as long as power is applied.

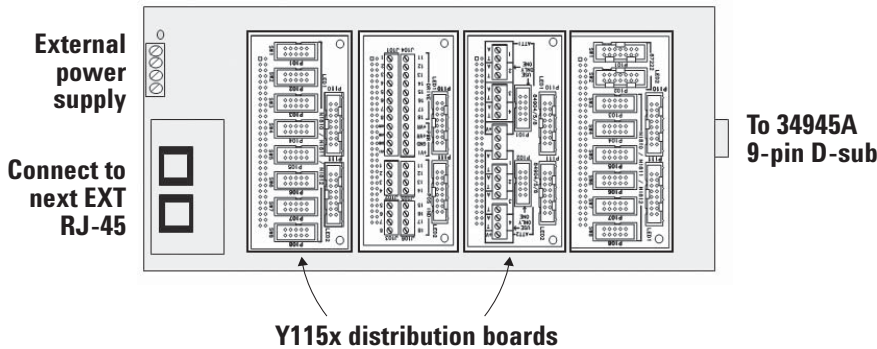

A disadvantage of continuous drive switches is they may change performance due to power dissipation in the switch housing. This can lead to deviations in performance of your test system.

Each 34945EXT can drive a total of 2 A continuously when using an external power supply. When using an L4445A or 34945A mainframe module to supply power to the 34945EXT, the power from any particular slot in the mainframe is limited to 24 volts at 100 mA continuous + 200 mA pulse for up to 15 ms (25% duty cycle). The module uses storage capacitors to provide short bursts of high current. This is ideal for switches or attenuators that use latching, pulsed relays.

Latching relays use pulse-mode drive because they use two coils per switch or attenuator section. A latching relay switch requires much lower overall current, since latching relays only require a short-duration pulse (typically 15 ms) of 100 mA to 300 mA. This permits the switch driver to control many more switches with a lower current supply. And, there is no constant current through the coils to heat up the switch housing.

Some vendor switch drivers only provide digital outputs for driving the relays. It is up to the user to distribute the power to the switches. Additional digital input and output modules would also need to be purchased to read switch position and display LED status. All of this is included in the 34945EXT, and the built-in Web Server provides a powerful, graphical interface for controlling and monitoring switches and attenuators.

Key RF and Microwave Test System Specifications

The choice of cables, connectors, and switches will significantly impact overall system performance and reliability. The cables, connectors, and switches create the signal path from the DUT to measurement instruments or other components. Ideally, there would be no signal degradation when routing from one point to another. For actual test systems, there is always some degradation of the signal in passing through cables, connectors, and switches. Signal degradation is directly related to signal frequency and the quality of switches and cables.

While poor quality cables and switches can significantly affect system performance at higher frequencies, it is not enough to have the best quality switches and cabling. You must also match source, cable, and load impedances. Any mismatch of impedances between the source and the load will cause a reflection of the source signal. A reflected signal adds or subtracts to the desired signal causing signal degradation, and the reflected signal can possibly damage the signal source.

Key parameters for custom RF/Microwave switching systems are listed below. This application note will concentrate more on switch specifications.

- Frequency range (bandwidth)
- Insertion loss
- Isolation
- VSWR
- Life
- Repeatability
- Termination

Frequency range

The top frequency limits of switches are set by the size of the coaxial structure and connectors. SMA connectors operate from DC to 20 GHz. SMB connectors operate from DC to 4 GHz. Switch specifications such as Insertion Loss, Isolation, and VSWR degrade with increasing frequency operation.

Insertion loss

Insertion loss is a measure of signal loss in the switch or signal path (in dB). It is a function of switch construction, cable types, cable lengths, cable connectors, dielectric material, cable-to-connector construction, and other components used in the signal path. For a switch, it is also a measure of how much power the switch will dissipate internally. Low insertion loss is important because power is expensive, especially at high frequencies. Insertion loss for quality switches is very low and ranges from 0.2 dB or less at low frequencies (DC to 4 GHz) to 0.6 dB at higher frequencies (20 GHz). Typically, flexible coax cables have 50% higher insertion loss compared to hand-conformable or semi-rigid coax cable. Flexible cables that exhibit low insertion loss at frequencies above 4 GHz can be very expensive.

Isolation (or crosstalk)

Isolation is a measure of signal attenuation between two signal paths (in dB). High isolation in switches is important to almost every measurement application, because it prevents unwanted signals from interfering with adjacent ports. High isolation is a key factor in determining the quality of a switch. High quality switches attenuate signals 90 dB to over 120 dB between ports at frequencies of DC to 4 GHz.

VSWR (or SWR)

VSWR is a way of measuring the amount of reflected power in a signal path. For a switch, it specifies how well the connectors and switch are matched to an ideal 50-ohm transmission line, for example. It is a measure of the ratio of the standing wave's highest voltage amplitude to the lowest voltage amplitude in the signal. Low VSWR is crucial in a test system when signal routing configurations involve multiple components in series. VSWRs of 1.1 to 1.5 are typical of high quality switches, representing 99.8% to 96% power transmission, respectively.

Life (reliability)

The life of a switch is usually specified in cycles, and a cycle represents switching from one position to another and back. Life specifies how many cycles the switch can be actuated and still maintain its specifications. Repeatability is closely tied to the life of the switch. Quality switches typically guarantee their specifications over the life of the switch, which can be over 5 million cycles! Some switch manufacturers specify life as the point at which the switch may experience mechanical failure. Therefore, signal degradation can actually occur much earlier.

Repeatability

Repeatability is a measure of the change of Insertion Loss from cycle to cycle (in dB) over the specified lifetime of the switch. Repeatability plays an important role in any test system. In automated test systems where switches are used for signal routing, every switch will add to the repeatability error. Such errors cannot be calibrated out of the system due to their random nature. Quality switches exhibit 0.03 dB variation in Insertion Loss over the specified life of the switch.

Termination

At high frequencies, all signals must be properly terminated. With improper termination (open end or mismatched impedance), signals can be reflected from the termination point back towards the source. This will result in an elevated VSWR and can even damage the signal source. Coaxial cables come in various characteristic impedances (typically 50 or 75 ohms), and the cable needs to be terminated in the same impedance. Termination usually takes place at the measurement instrument or DUT. However, when a source instrument is switched out of the active path, it should be switched to a properly terminated load. This can be accomplished by purchasing multi-port switches that terminate inactive ports. Although a good test procedure always turns the source OFF before switching, sometimes that is not possible, so the active source needs to be terminated.

Many switch manufacturers orient their literature towards Frequency, Insertion Loss, Isolation, and VSWR. However, Repeatability and Life can be absolutely critical to the quality of the test system. It may be necessary to contact vendors and have them explain the change in insertion loss over the duration of the lifetime use of the switch.

Isolation, Repeatability, and Life significantly affect the cost of an RF/Microwave switch, and they also greatly affect the signal integrity of the test system. Manufacturing quality of these three parameters strongly correlates to the integrity of the remaining parameters.

Tips in Building an RF/Microwave Test System

Where do you start in building a test system? The following guidelines are not comprehensive for all test systems, but they do offer a good foundation from which you can build your test system plan.

1. Understand and document the test system requirements relative to testing the DUT. The system requirements should include how the operator interacts with the test system. This will drive the equipment needs, system configuration, and the requirements for diagnostic tools.
2. Choose stimulus and response equipment that exceed your measurement requirements, since there will always be some degradation of signal between the instruments and the DUT via the switching subsystem.
3. Choose switches, attenuators, and connectors that minimize signal degradation and exceed the frequency requirements of your system. If switches need to be positioned close to the DUT, you will need to control the relay coils with a dedicated Switch Driver, general purpose relays, or digital outputs. You may also need switches that create a straight-through path that bypasses attenuators or amplifiers in order to calibrate and verify your system.
4. Choose coax cabling with connectors that minimize insertion loss in the system. Does the system need to be re-configured? If so, you may need to use flexible coax cabling. Achieving low insertion loss at high frequencies while maintaining a flexible cable setup can be challenging and expensive. Choose your cable vendor carefully, since the quality of the construction of the cable will significantly affect overall system performance.
5. Delay lines and phase matching between signal paths demand very tight dimensional tolerances. You may need to use semi-rigid cable to achieve those requirements. This will likely require the use of external, discrete switches.

6. Choose a switching sub-system that is easy to configure, verify, and provides the capacity to expand your test system in the future. How you control external switches is a key factor, since you may require position indication that gives the actual state of the switch (vs. the programmed state of the switch).
7. Once your system is assembled, make detailed measurements with the DUT in place for every path and understand such performance factors as impedance matching, phase delay, and insertion loss.
8. Software will play a key role in controlling your signal path. A switch executive can provide you with mutual exclusion of switches, so you do not inadvertently drive two sources together. This can be done within the switch subsystem or through a software driver supplied with the switch system.

It is recommended that you keep signal paths as short as possible to improve signal integrity. Long signal paths contribute to rising edge and phase delay, because those paths consist of lead resistance and capacitance. Phase delay distortions produce ringing, overshoot, and undershoot. In some systems, phase matching is required, and signal paths must match impedance and length. High speed digital signals exhibit RF behavior in real world devices and are directly affected by edge and phase delays.

System accuracy is also affected by the number of components (switches, attenuators, amplifiers, RF couplers, dividers) and connector adapters between the source and the DUT. For increased system accuracy in the presence of strong adjacent signals flowing in the test system, it is sometimes necessary to add cascaded switches, route signals carefully, and provide shielding around sensitive signal paths.

Key Factors in Selecting RF/Microwave Switches

There are several key factors a switch should provide for an RF/Microwave test system. The parameters covered in the previous sections will now be used to identify the right type of switch:

1. The insertion loss, VSWR, and isolation at the desired frequencies must not compromise the measurement. Signal degradation through the switch can be minimized by using high quality switches configured with proper connectors.
2. Long life and high repeatability between switch cycles will improve test system integrity.
3. The switch should provide position feedback, so you can determine the actual path of the signal instead of only the programmed state.

When selecting RF/Microwave switches, be aware that the most common and readily available switches often present a minimum viable solution. The cost of the switch goes up considerably when adding options to achieve the desired level of repeatability, performance, and usability. A test system that gives varying results over time or is difficult to troubleshoot is often an indication of lower quality switches and cables.

Minimum viable RF/Microwave switches typically have the following features:

- Switches are Normally Open (Failsafe) and driven by a single coil. These coils are continuously energized and require 100 mA-300 mA (24 V) of constant current per coil. When power is removed, the switch opens.
- Switches have solder-lugs or bare wires rather than easy to use D-sub socket connectors.
- No position feedback is included to electrically determine the state of the switch
- Bandwidth of switch is lower
- Isolation is typically 50 – 80 dB
- Switches are only specified for 1 million cycles and don't include repeatability specs
- Switches provide no protection diodes when driving relay coils
- Switches are unterminated

A test system with many Failsafe-type switches requires a significant amount of current to maintain switch closures. Some RF /Microwave Switch Drivers can actually drive over 20 A of current to control these types of switches. They require a high-current power supply and the routing of relatively high-gage wires to and from the driver module, power supply, and switch.

Switch manufacturers provide latching-relay switches that only require a 10-20 ms pulse of current to change the state of the switch. This doubles the number of coils in the switch housing, increases the size of the switch housing, and adds cost. However, wiring and power requirements will be much easier to implement.

Test engineers and operators of test systems often need visual feedback to understand and troubleshoot the test system. Without position feedback hardware inside the switch, it can be difficult to determine the switch's actual state. LED indicators are also commonly mounted on an operator panel to indicate the active signal path. Position feedback is usually read by digital inputs and use separate digital outputs to drive LEDs.

Some vendor's Switch Drivers are really just high current Digital Output hardware. They only energize the relay coil, so position feedback and LED drivers must be provided by additional Digital Input and Output hardware. Add this to the complexity of power distribution, and you end up with an expensive solution that is also difficult to troubleshoot when failures occur.

Controlling Agilent Switches and Attenuators

The Agilent 34945A/L4445A Switch/Attenuator Driver is optimized to drive Agilent switches and attenuators, although it can be used to drive virtually any discrete switch or attenuator. This section will show you how to select options for Agilent switches and attenuators to configure the most efficient and easy-to-use system. Here are the recommended attributes:

- 24 V latching, relay coils configured for open-collector, pulsed-mode operation
- Position Feedback to sense the actual state of the switch
- D-sub connector mounted on device to simplify wiring

RF/Microwave switches/attenuators are most often 24 V devices, and there is good reason. 24 V coils draw significantly less current than 12 V or 5 V coils. In many cases, you actually pay more for 12 V or 5 V coils. Selecting 24 V relay coils simplifies this process and permits you to drive switches without an external power supply when connecting to the first 34945EXT module.

Position feedback is often a standard feature with Agilent switches, because the construction of the switch drive signals can also feed back information about the state of the switch. D-sub socket connectors allow for the easiest connection to Y115x distribution boards.

There are other options than can be purchased or specified for switches/attenuators. Here are a few that are worthy of comment:

- TTL/CMOS drive
- Solder lugs
- Current interrupts

The 34945EXT can drive switches with TTL/CMOS control signals. However, this option usually adds cost to the switch, and it forces all switches connected to the Y115x to use the same drive mode. Solder lugs may appear to be cheaper with some switches, but you should consider the labor costs and reliability. In many cases, the standard configuration of the switch is a D-sub connector, so you may actually pay more for solder lugs. And, finally, current interrupts almost always add cost to the switch.

They allow you to apply a constant voltage to a switch, and the switch actuates to create its own pulsed mode to change states. Current interrupts do offer the fastest programming time, because the switch actuates as fast as it can rather than the timed response of a pulse-mode control circuit.

The Y115x distribution boards are the interface between the 34945EXT and the switches/attenuators. It is the 34945EXT that actually performs all the control and sensing operations. The Y115x boards simply provide cable headers and/or screw terminals that interface a large number of Agilent switches and attenuators to the 34945EXT.

Each 34945EXT can drive up to 64 coils, where each of four Y115x boards route the control of relay coils, the position feedback, and the drive for external LEDs for up to 16 coils. Some devices require two or more coils and provide varying ways of indicating position feedback. The Y115x boards handle all of those signals for you. You need only provide a simple ribbon cable with standard socket connectors.

Let's take a closer look at one of the 34945EXT's distribution boards, so you can better understand how to interface to external switches and attenuators. The image on the following page shows a view of the Y1153A Distribution board. It is designed to control a wide range of Agilent attenuators and supports either a ribbon cable/connector or screw terminal connection.

Each LED socket header represents the state of up to eight coils, and each vertical lead-pair connects to the LED, representing the section position. You can route a ribbon cable with a 16-pin connector up to your control panel viewing area. Or, you can mount LED's on a socket connector and plug them directly into the socket header on the board.

Relay control and position feedback is provided in either a socket header or with screw terminals for the Y1153A. Most of the Y115x boards have socket headers for easy connection to Agilent switches and attenuators.

Pulse drive, coil voltage, position feedback, bandwidth, connectors, and termination represent a complex set of options in selecting any switch. However, this process is made easier by first matching switches and attenuators with the correct Y115x distribution board.

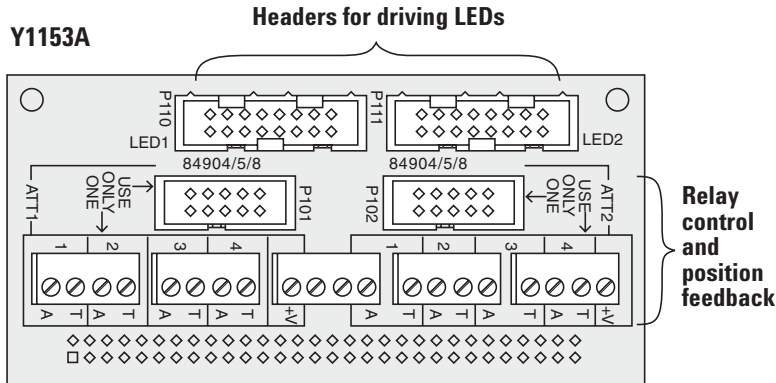

34945EXT Distribution Board Configuration

Steps to select and configure the 34945EXT associated distribution boards, relays, attenuators & cabling:

If the relays required for your design have not been ordered:

If the relays required for your design can be procured with the recommended options, cable construction and system configuration becomes very simple. Follow these steps below:

1. First, find the Agilent switch or attenuator required along the leftmost columns in Table 1 and Table 2. Adjacent columns show the recommended options for the relays. If these relays and options are ordered, cable construction, indicator read back and power becomes very simple.

2. Next, notice that the rightmost columns specify which distribution board to use and how many of the switches or attenuators are supported on each board. Notice that some boards support multiple devices.
3. Finally, once you know which distribution board(s) to use, refer to specific distribution card table for details on the associated distribution boards(s). Following each Y115x table, there will be insights and instructions for using the particular Y115x board. Also included are part numbers and instructions for building ribbon cables that connect from the distribution board socket headers to the switch connectors. Also, refer to the 34980A & L4445A user manual for additional details for the construction of these cables.

4. Note that distribution board Y1155A is special in that it has screw terminals for all driver and indicator connections. This distribution board is appropriate for relays which only have solder connections and as such, a discrete wire is the most appropriate interconnect method. For these cases the cable assembly is a simple multi-wire bundle.

If the relays for your design are already on hand:

If you already have your relays, and they are not listed in Table 1 or Table 2, the 34945EXT may still be able to successfully drive your device using the Y1155A distribution board. However, the relay coil drive characteristics will need evaluation to verify for compatibility. In this case, you would use the distribution board Y1155A and direct wire the relay drive lines to the screw terminals on the distribution board. See the section “Custom Switching and the 34945/L4445A Switch Driver” for further instructions.

The following kits contain parts to build cables between the Y115x boards and the specified connectors on the Agilent switches and attenuators.

Table 1. Agilent Switch/Attenuator to Y115x Distribution Board

Agilent Model	Recommended Switch Options			Description	Frequency Range	34945EXT Distribution Board					
	Coil Voltage Option	Indicator Option	DC Drive Connector Option (style)			Number of Switches Supported					
						Y1150A (Table 3)	Y1151A (Table 4)	Y1152A (Table 5)	Y1153A (Table 6)	Y1154A (Table 7)	Y1155A
N1810UL	124	402	201(DB9F)	Unterminated latching 3-port (SPDT)	DC to 2, 4, 20, or 26.5 GHz	8		2		6	
N1810TL	124	402	201(DB9F)	Terminated latching 3-port (SPDT)	DC to 2, 4, 20, or 26.5 GHz	8		2		6	
N1811TL	124	402	201(DB9F)	Terminated latching 4-port (bypass)	DC to 2, 4, 20, or 26.5 GHz	8		2		6	
N1812UL	124	402	201 (DB9F)	Unterminated latching 5-port	DC to 2, 4, 20, or 26.5 GHz	8		2		6	
87104A	024	--	161(16DIP)	SP4T 4-port latching, terminated	DC to 4 GHz		2				
87104B	024	--	161(16DIP)		DC to 20 GHz		2				
87104C	024	--	161(16DIP)		DC to 26.5 GHz		2				
87106A	024	--	161(16DIP)	SP6T 6-port latching, terminated	DC to 4 GHz		2				
87106B	024	--	161(16DIP)		DC to 20 GHz		2				
87106C	024	--	161(16DIP)		DC to 26.5 GHz		2				
87204A	--	--	161(16DIP)	SP4T 4-port latching, terminated	DC to 4 GHz			1			
87204B	--	--	161(16DIP)		DC to 20 GHz			1			
87204C	--	--	161(16DIP)		DC to 26.5 GHz			1			
87206A	--	--	161(16DIP)	SP6T 6-port latching, terminated	DC to 4 GHz			1			
87206B	--	--	161(16DIP)		DC to 20 GHz			1			
87206C	--	--	161(16DIP)		DC to 26.5 GHz			1			
87222C	--	--	161(16DIP)	4-port transfer switch	DC to 26.5 GHz					2	
87222D	--	--	161(16DIP)		DC to 40 GHz					2	
87222E	--	--	161(16DIP)		DC to 50 GHz					2	
87406B	024	--	161(16DIP)	6-port matrix, terminated	DC to 20 GHz		2				
87606B	--	--	161(16DIP)		DC to 20 GHz			1			
L7104A	024	--	161 (16DIP)	SP4T 4-port switch latching, terminated	DC to 4 GHz		2				
L7104B	024	--	161 (16DIP)		DC to 20 GHz		2				
L7104C	024	--	161 (16DIP)		DC to 26.5 GHz		2				
L7204A	024	--	161 (16DIP)	SP4T 4-port switch latching, un-terminated	DC to 4 GHz		2				
L7204B	024	--	161 (16DIP)		DC to 20 GHz		2				
L7204C	024	--	161 (16DIP)		DC to 26.5 GHz		2				
L7106A	024	--	161 (16DIP)	SP6T 6-port switch latching, terminated	DC to 4 GHz		2				
L7106B	024	--	161 (16DIP)		DC to 20 GHz		2				
L7106C	024	--	161 (16DIP)		DC to 26.5 GHz		2				
L7206A	024	--	161 (16DIP)	SP6T 6-port switch latching, un-terminated	DC to 4 GHz		2				
L7206B	024	--	161 (16DIP)		DC to 20 GHz		2				
L7206C	024	--	161 (16DIP)		DC to 26.5 GHz		2				
L7222C	--	--	161 (16DIP)	4-port transfer switch latching, terminated	DC to 26.5 GHz					2	

Table 1. Agilent Switch/Attenuator to Y115x Distribution Board (Continued)

Agilent Model	Recommended Switch Options			Attenuator Description	Frequency Range	34945EXT Distribution Board Number of Switches Supported					
	Coil Voltage Option	Indicator Option	DC Drive Connector Option (style)			Y1150A (Table 3)	Y1151A (Table 4)	Y1152A (Table 5)	Y1153A (Table 6)	Y1154A (Table 7)	Y1155A (Table 7)
84904K	024	--	--(10DIP)	11 dB max, 1 dB steps, 4 sections	DC to 26.5 GHz				2		
84904L	024	--	--(10DIP)		DC to 40 GHz				2		
84904M	024	--	--(10DIP)	11 dB max, 1 dB steps, 4 sections	DC to 50 GHz				2		
84905M	024	--	--(10DIP)		60 dB max, 10 dB steps, 3 sections	DC to 50 GHz				2	
84906K	024	--	--(10DIP)	90 dB max, 10 dB steps, 4 sections	DC to 26.5 GHz				2		
84906L	024	--	--(10DIP)		DC to 40 GHz				2		
84907K	024	--	--(10DIP)	70 dB max, 10 dB steps, 3 sections	DC to 26.5 GHz				2		
84907L	024	--	--(10DIP)		DC to 40 GHz				2		
84908M	024	--	--(10DIP)	65 dB max, 5 dB steps, 4 sections	DC to 50 GHz				2		
8494G	024	--	060(Viking to wire)		11 dB max, 1 dB steps, 4 sections	DC to 4 GHz				2	
8494H	024	--	060(Viking to wire)		DC to 18 GHz				2		
8495G	024	--	060(Viking to wire)	70 dB max, 10 dB steps, 3 sections	DC to 4 GHz				2		
8495H	024	--	060(Viking to wire)		DC to 18 GHz				2		
8496G	024	--	060(Viking to wire)	110 dB max, 10 dB steps, 4 sections	DC to 4 GHz				2		
8496H	024	--	060(Viking to wire)		DC to 18 GHz				2		
8495K	--	--	060(Viking to wire)	70 dB max. 10 dB steps, 4 sections	DC-26.5 GHz				2		
8497K	024	--	060(Viking to wire)		90 dB max. 10 dB steps, 4 sections	DC-26.5 GHz				2	

Notes: Numbers listed in the column represent the maximum number of switches which may be connected to the distribution board. Switch models may be combined up to the maximum listed. In the case of the Y1152A & Y1154A, the N181x style connector is a 10 pin (2x5) while the other switches listed are 16 pin (2x8), so both switch styles may be used up to their corresponding maximums. "--" means the preferred switch configuration for voltage, indicator and/or connector comes standard with the base part number

Table 2. Agilent Switch to Y1155 Distribution Board

Agilent Model	Recommended Options			Description	Frequency range	34945EXT Distribution Board					
	Coil Voltage Option	Indicator Option	Connector Option (style)			Number of Switches Supported					
						Y1150A (Table 3)	Y1151A (Table 4)	Y1152A (Table 5)	Y1153A (Table 6)	Y1154A (Table 7)	Y1155A
8762A	024	N/A	-- (solder terminal)	Terminated latching 3-port (SPDT)	DC to 4 GHz						8
8762B	024	N/A	-- (solder terminal)		DC to 18 GHz						8
8762C	024	N/A	-- (solder terminal)		DC to 26.5 GHz						8
8762F	024	N/A	-- (solder terminal)	75 ohms terminated (SPDT)	DC to 4 GHz						8
8763A	024	N/A	-- (solder terminal)	Terminated latching 4-port (transfer)	DC to 4 GHz						8
8763B	024	N/A	-- (solder terminal)		DC to 18 GHz						8
8763C	024	N/A	-- (solder terminal)		DC to 26.5 GHz						8
8764A	024	N/A	-- (solder terminal)	Terminated latching 5-port	DC to 4 GHz						8
8764B	024	N/A	-- (solder terminal)		DC to 18 GHz						8
8764C	024	N/A	-- (solder terminal)		DC to 26.5 GHz						8
8765A	324	N/A	324 (solder terminal)	Coaxial (SPDT), SMA	DC to 4 GHz						8
8765B	324	N/A	324 (solder terminal)	Coaxial (SPDT), SMA	DC to 20 GHz						8
8765C	324	N/A	324 (solder terminal)	Coaxial (SPDT), 3.5 mm	DC to 26.5GHz						8
8765D	324	N/A	324 (solder terminal)	Coaxial (SPDT), 2.4 mm	DC to 40 GHz						8
8765F	324	N/A	324 (solder terminal)	Coaxial switch, (SPDT) 75 ohm, SMB	DC to 4 GHz						8
8766K	024	N/A	060 (Viking to wire)	Coaxial switch, (SP3T)	DC-26.5 GHz						2
8767M	024	N/A	see notes	Coaxial switch, (SP4T)	DC-50 GHz						2
8767K	024	N/A	060 (Viking to wire)	Coaxial switch, (SP4T)	DC-26.5 GHz						2
8768K	024	N/A	060 (Viking to wire)	Coaxial switch, (SP5T)	DC-26.5 GHz						1
8768M	024	N/A	see notes	Coaxial switch, (SP5T)	DC-50 GHz						1
8769K	024	N/A	060 (Viking to wire)	Coaxial switch, (SP6T)	DC-26.5 GHz						1
8769M	024	N/A	see notes	Coaxial switch, (SP6T)	DC-50 GHz						1
N9397A	--	N/A	-- (solder terminal)	8 GHz Solid State Switch	300 kHz-8 GHz						8
N9397C	--	N/A	-- (solder terminal)	18 GHz Solid State Switch	300 kHz-18 GHz						8
U9397A	--	N/A	-- (solder terminal)	8 GHz Solid State Switch	300 kHz-8 GHz						8
U9397C	--	N/A	-- (solder terminal)	18 GHz Solid State Switch	300 kHz-18 GHz						8

Notes: The number listed in the column is the maximum number of switches which may be connected within each switch model type as limited by the total number of available drivers.
A total number of 16 drivers are available, and it is possible to mix switch models on one Y1155A until all 16 drivers are used.
The number of drivers required by each switch varies. See the switch datasheet for details
For 876xM relays, recommended cable accessory P/N 11764-60001 (10 DIP to wire) needs to be purchased separately.
"--" means the preferred switch configuration for voltage, indicator and/or connector comes standard with the base part number

Tables 1-7 will describe which kits are appropriate for the various switches and attenuators.

Agilent Y1157A Cable Kit

- 9 to 10-pin cable kit for Y1150A, Y1152A, and Y1154A
- Supplies to build 4 cables
- Contains:
 - Four 9-pin Dsub IDC M
 - Four 10-pin IDC F
 - Four 10-pin strain relief
 - Four meters of 9 conductor ribbon cable

Agilent Y1158A Cable Kit

- 10 to 10-pin or 10 to 14-pin cable kit for Y1153A and Y1154A
- Supplies to build 2 cables
- Contains:
 - Four 10-pin IDC F
 - Four 10-pin strain relief
 - Two 14-pin IDC F
 - Two 14-pin strain relief
 - Two meters of 10 conductor ribbon cable

Agilent Y1159A Cable Kit

- 16 to 16-pin cable kit for LED socket connections
- Also used for Y1151A and Y1152A for connecting switches
- Supplies to build 2 cables
- Contains:
 - Four 16-pin IDC F
 - Four 16-pin strain relief
 - Two meters of 16-conductor ribbon cable

Table 3.
The Y1150A Distribution Board

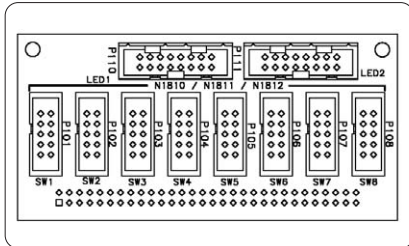

Y1150A	Switch options
Coil voltage (24 V)	124
Position feedback	402
Connector type (9-pin)	201
Switch types: N1810UL, N1810TL, N1811TL, N1812UL	
Cable: 9-pin to 10-pin	

These are latching relays, so each switch uses two of the 16 coil drivers available through the distribution board. Therefore, eight switches can be controlled by this board. 34945EXT channels are paired to drive dual relays: 1:11, 2:12, 3:13, etc. Switches are driven with a 15 ms pulsed voltage. LED's are paired together, left to right, representing Channels one to eight. You can construct a 9-pin to 10-pin cable to connect the Agilent switch to the Y1150A distribution board.

Here is an example of commonly accessible part numbers for building a cable. All parts can be found at popular electronics distributors (e.g. Digi-Key or

Newark), or you can purchase the Y1157A, Y1158A, or Y1159A kits illustrated below:

- **Ribbon Cable:**
3M P/N 3365/09 (28 AWG)
- **Y1150A Connector:**
10-pin socket connector, IDC termination.
3M P/N 89110-0101
- **N181x Connector:**
9-pin D-sub male, IDC termination.
3M P/N 8209-6000
- **Y1157A Kit:**
One kit supplies parts to build four switch cables.
- **Y1159A Kit:**
One kit supplies parts to build two cables to connect to LEDs
- **Wire Pin 1 to Pin 1**
with pin 10 on Y1150A connector unused
- See the 34980A or L4445A user manual for cable construction details

Table 4.
The Y1151A Distribution Board

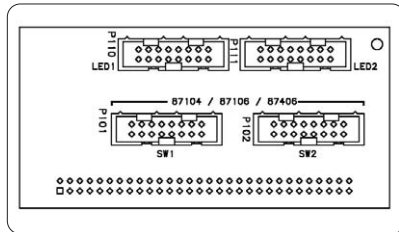

Y1151A	Switch options
Coil voltage (24 V)	024
Position feedback	Comes Standard
Connector type (16-pin)	161
Switch types:	
87104, 87106, 87406, L7104, L7106, L7204, L7206	
Cable: 16-pin to 16-pin	

Each multi-port switch requires up to eight coil drivers, so this board can drive two such switches. LED's work from left to right with each representing a particular port of the switch. This switch comes standard with position feedback. You can construct a 16-pin to 16-pin cable to connect the switch to the Y1151A distribution board.

Here is an example of commonly accessible part numbers for building a cable. All parts can be found at popular electronics distributors (e.g. Digi-Key or

Newark), or you can purchase the Y1157A, Y1158A, or Y1159A kits illustrated below:

- **Ribbon Cable:**
3M P/N 3365/16 (28 AWG)
- **Y1151A Connector:**
16-pin socket connector, IDC termination.
3M P/N 89116-0101
- **Switch Connector:**
16-pin socket connector, IDC termination.
3M P/N 89116-0101
- **Y1158A Kit:**
One kit supplies parts to build two switch cables.
- **Y1159A Kit:**
One kit supplies parts to build two cables to connect to LEDs
- Wire Pin 1 to Pin 1

Table 5.
The Y1152A Distribution Board

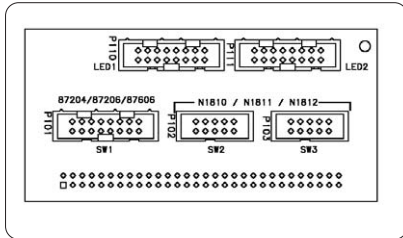

Y1152A	Switch options
Coil voltage (24 V)	Comes Standard
Position feedback	Comes Standard
Connector type (16-pin)	161
Switch types: 87204, 87206, 87606, N181x (see Y1150A)	
Cable: 16-pin to 16-pin and 9-pin to 10-pin	

This board is a hybrid that can drive different types of switches. A 6-port switch requires twelve coil drivers. With four coil drivers remaining available, two N181x switches can be added. This is actually a fairly common situation. Test systems often need a combination of SP6T and SP2T switches.

LED's are paired from left to right representing open/closed per port. The N181x switches use the rightmost four LED's in a paired configuration: OPEN/CLOSED/OPEN/CLOSED.

Please refer to the Y1150A for information on building a cable for the N181x switches. Here is an example of commonly accessible part numbers for building a cable for the 87x0x switches. All parts can be found at popular electronics distributors (e.g. Digi-Key or

Newark), or you can purchase the Y1157A, Y1158A, or Y1159A kits illustrated below:

- **Ribbon Cable:**
3M P/N 3365/16 (28 AWG)
- **Y1152A Connector:**
16-pin socket connector, IDC termination.
3M P/N 89116-0101
- **Switch Connector:**
16-pin socket connector, IDC termination.
3M P/N 89116-0101
- **Y1157A Kit:**
One kit supplies parts to build four switch cables for N181x
- **Y1159A Kit:**
One kit supplies parts to build two switch cables
- **Y1159A Kit:**
One kit supplies parts to build two cables to connect to LEDs
- Wire Pin 1 to Pin 1

Table 6.
The Y1153A Distribution Board

Y1153A.1	Switch options
Coil voltage (24 V)	024
Position feedback	Comes Standard
Connector type (10-pin)	Comes Standard
Switch types: 84904, 84905, 84906, 84907, 84908	
Cable: 10-pin to 10-pin	

Y1153A.2	Switch options
Coil voltage (24 V)	024
Position feedback	Comes Standard
Connector type (Viking 9-pin)	060
Switch types: 8494, 8495, 8496	
Cable: Viking to bare wire (see color-code in figure)	

This board can control up to two discrete attenuators which have either three or four attenuator sections. Each attenuator section requires two coil drivers to switch attenuator sections IN or OUT of the signal path. A 4-section attenuator would require eight coil drivers. Two attenuators require 16 coil drivers, so all of the available coil drivers are used to drive two attenuators.

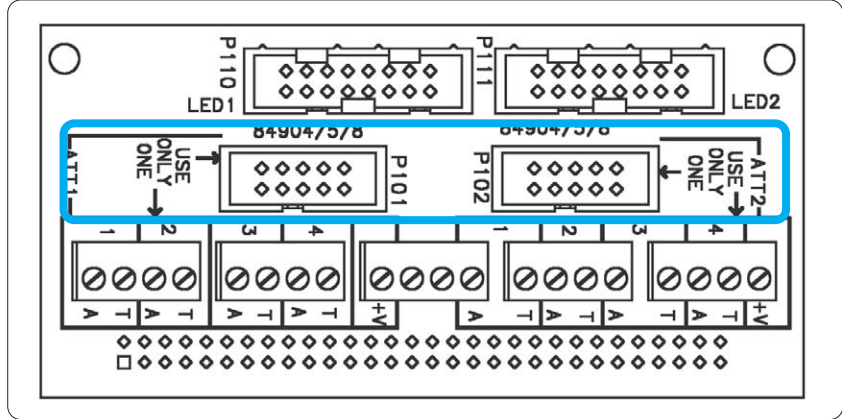

Y1153A.1

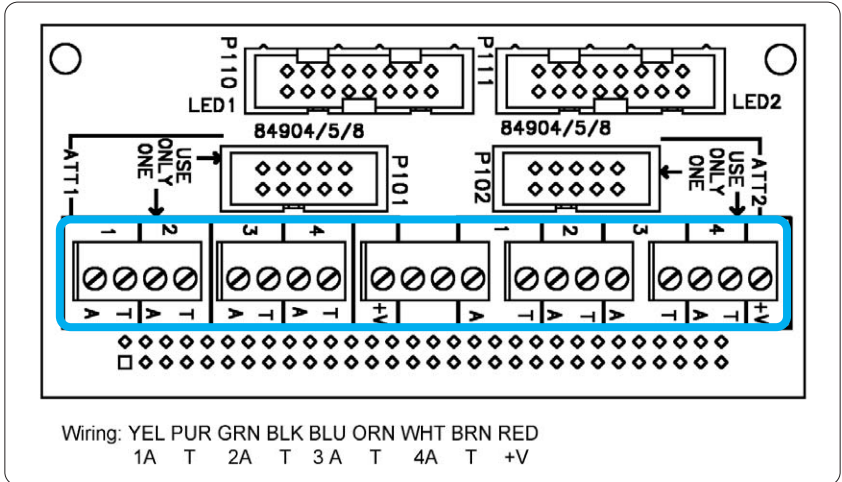

Y1153A.2

The Agilent 8494/5/6 attenuators come standard with a Viking connector and a Viking to bare wire cable. The Agilent 8490x attenuators use a 10-pin socket header. Both are supported on the Y1153A. The As and Ts are nomenclature that represent Attenuator or pass-through, so the attenuator section is either inline or bypassed. Position feedback is cleverly combined with the drive lines to indicate which section has been selected. That is reflected in the LEDs which represent the selected sections.

LEDs are paired, left to right. Two LEDs are used per section. LED1 socket header supports Channels one to four. Logic sense can be inverted to have LEDs representing attenuation or pass-through.

Wiring for the Viking to bare wire connection is indicated in the **Table 6**. Here is an example of commonly accessible part numbers for building a cable for the 8490x attenuators. All parts can be found at popular electronics distributors (e.g. Digi-Key or Newark), or you

can purchase the Y1157A, Y1158A, or Y1159A kits illustrated below:

- **Ribbon Cable:**
3M P/N 3365/10 (28 AWG)
- Y1153A Connector:
10-pin socket connector, IDC termination.
3M P/N 89110-0101
- 8490x Connector:
10-pin socket connector, IDC termination.
3M P/N 89110-0101
- Y1157A Kit:
One kit supplies parts to build four attenuator cables
- Y1159A Kit:
One kit supplies parts to build two cables to connect to LEDs
- Wire Pin 1 to Pin 1

Table 7.
The Y1154A Distribution Board

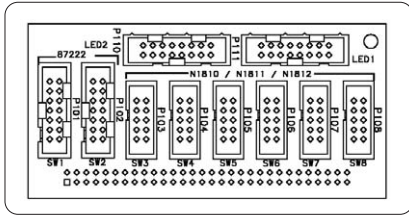

Y1154A	Switch options
Coil voltage (24 V)	Comes Standard
Position feedback	Comes Standard
Connector type (10-pin)	161
Switch types:	
87222, N181x (see Y1150A), L7222C	
Cable: 10-pin to 14-pin and 9-pin to 10-pin	

This board is a hybrid since it supports two different types of switches. Most test systems rarely need more than two Agilent 87222 transfer switches. The Agilent 87222 transfer switches only use two coil drivers each, so twelve coil drivers remain available. This permits an additional six N181x switches to be added to this distribution board. LEDs are paired from left to right in an OPEN/CLOSE, OPEN/CLOSE manner.

Please refer to the Y1150A for information on building a cable for the N181x switches. Here is an example of commonly accessible part numbers for building a cable for the 87222 switches. Note that a 14-pin to 10-pin cable will be required. Pins 11-14 will not be used. This was done to avoid accidentally plugging an N181x or 87222 into the wrong socket.

All parts can be found at popular electronics distributors (e.g. Digi-Key or Newark), or you can purchase the Y1157A, Y1158A, or Y1159A kits illustrated below:

- **Ribbon Cable:**
3M P/N 3365/10 (28 AWG)
- **Y1152A Connector:**
14-pin socket connector, IDC termination.
3M P/N 89114-0101
- **87222 Connector:**
10-pin socket connector, IDC termination.
3M P/N 89110-0101
- **Y1157A Kit:**
One kit supplies parts to build four switch cables for N181x
- **Y1158A Kit:**
One kit supplies parts to build two switch cables to 87222 switches
- **Y1159A Kit:**
One kit supplies parts to build two cables to connect to LEDs
- Wire Pin 1 to Pin 1

Y1155A

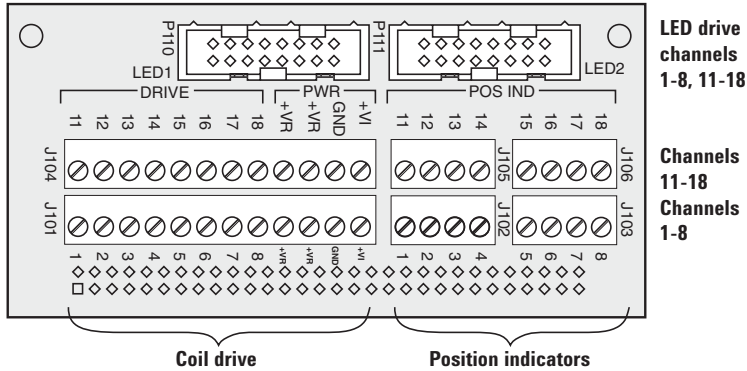

Custom Switching and the 34945A/L4445A Switch Driver

The Y1150A through Y1154A provide very specific solutions for connecting to a wide range of Agilent switches and attenuators. You may already have Agilent or non-Agilent switches and attenuators that are not directly supported by those distribution boards. The Y1155A is designed to handle all other configurations.

There are three main sections:

- **Coil Drive**
(Higher current Digital Output – pulsed or continuous)
- **Position Indicators**
(Open collector or TTL/CMOS Digital Input)
- **LED Drive**
(Low current Digital Output)

Coil Drive

Each Y1155A can drive up to 16 coils in either Pulsed or Continuous mode. Pulsed mode means a 5 ms to 255 ms pulse of the supply voltage or TTL level is used to drive the coil.

Continuous mode channels are just Digital Outputs. When you close a Normally Open, non-latching switch, you are constantly applying the drive signal to the switch's relay coil. To open the channel, the drive signal is removed. Using 24 V relays, the typical current drain would be 100 mA to 300 mA for each switch; however, 5 V relays could draw over 500 mA.

When powered by an external supply, a single 34945EXT limits its overall current to 2 A. This means you could typically drive 5 to 10 Normally Open 24 V switches when using an external power supply. If you rely upon the 34945A or L4445A to supply the 24 V to the first 34945EXT, its output current is limited to 100 mA continuous + 200 mA pulsed for 15 ms, (25% duty cycle). The 34945A/L4445A uses storage capacitors that permit higher current for short duration pulses.

Current limitations are rarely, if ever, a problem for Pulsed mode, since only one relay at a time is pulsed for only 15 ms (default). Pulsed mode switches use two coils and operate in a latching mode. Each switch requires a Paired Channel. Where Continuous Mode relays can use channels 1-8 or 11-18, Pulsed Mode switches use two paired channels together: Channel 1/11, 2/12, 3/13, etc. The OPEN operation pulses the lower channel coil, and the CLOSE pulses the upper channel coil.

The 34945EXT only supports Common Positive coil drive, so you must connect the common connection on the switch to the +VR lines on the Y1155A, and the switch must use Common Positive drive circuits.

Position Indicators

These are just Digital Inputs that respond to the same voltage level as the coil drive or TTL signals. The 34945EXT allows inverting the polarity of the position indicator input, so you can indicate the desired logic level. For Continuous Mode channels, you can wire the Coil Drive channel to the Position Indicator channel. If you have position indicator signals coming from the switch, you can hook them to the position indicator channel. +VR and

Ground are available on the Y1155A board to drive position indication.

LED Drive

Each LED senses the position indicator logic level. Sense inversion can be set, so the LED goes ON or OFF, dependent upon the logic sense of the Position Indicator Channel. Each vertical pair of pins represents 1 of 16 channels. The +V, Anode, side is the bottom row, and the Cathode side is the top row which is driven by the Position Indicator. For paired channels, the OPEN/CLOSE would cause LEDs to be lit between both socket headers (e.g. Channels 1/11), instead of being paired together as you would find in the Y1150A through Y1154A boards.

Example: driving an Agilent 33311B Microwave Switch

The 33311B is a latching switch that automatically disengages current (Current Interrupts) after about 25 ms. Therefore, you can use Pulse Mode or Continuous Mode on this type of switch. Once the switch changes state, you can monitor the drive lines to detect the state of the switch.

The Common Positive terminal (C+) is connected to the +VR on the card for open collector operation. Connection 1 (C1) is wired to the OPEN side, Channel 1; Connection 2 (C2) is wired to the CLOSE side, Channel 11. Channels 1 and 11 are paired together using the Web Server. Drive wires are connected to the associated Position Indicators. The sense logic can be inverted, if necessary to achieve the desired results. The leftmost LED in each bank will light when opening and closing the switch.

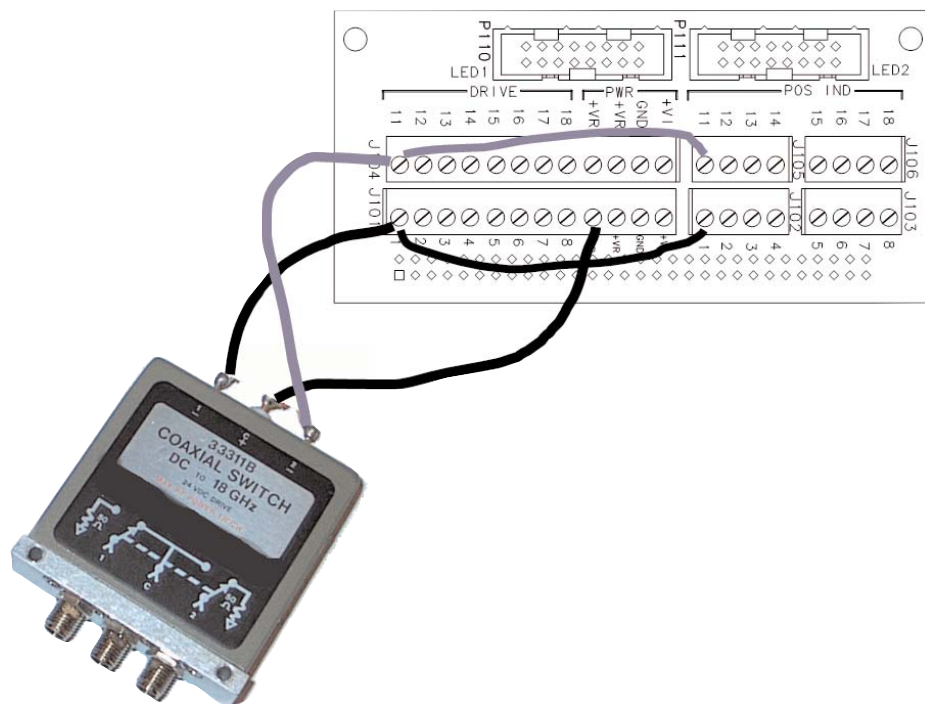

If this were a normally open switch with a single coil, you would only connect to a single channel and use continuous mode. Everything would be wired the same except there would only be two wires coming from the switch.

Example 34945A/L4445A Switch Driver Configurations

The following two examples should give you a pretty good idea of how to configure a typical RF/Microwave Switch system based upon the Agilent 34980A and 34945A/L4445A Switch Driver.

Example #1:

A test system is being built that requires the following Microwave Switching:

- (4) DC-18 GHz SP6T Switches
- (7) DC-18 GHz SPDT Switches

We will choose switches that are latching, use 24 V coils, have position feedback, and socket connectors, where possible.

Looking at **Table 1**, we choose the Agilent 87206B DC-20 GHz, SP6T switches. That switch can be driven by the Y1152A Distribution board. Four SP6T switches require four Y1152A's. Notice that each Y1152A can also drive two N181x switches. If we choose the N1810UL switch, then all seven switches can be driven by the four Y1152A distribution boards. Each switch will be ordered with options for 24 V coils, Position Indicators, and socket connectors, as shown in **Tables 3** and **5**.

Here is the final recommended configuration:

- (4) 87206B DC-20 GHz SP6T Switches
- (7) N1810UL DC-20 GHz SPDT Switches
- (1) 34980A Switch/Measure Unit
- (1) 34945A Switch/Attenuator Driver w/cable
- (1) 34945EXT
- (4) Y1152A Distribution Modules
- (2) Y1157A Cable Kits for N1810UL switches
- (2) Y1158A Cable Kits for 87206B switches
- Optional (4) Y1159A Cable Kits for LEDs

If using the L4445A Switch/Attenuator, simply replace 34980A, 34945A, and 34945EXT above with a single L4445A. (It comes with a single 34945EXT).

Note that since 24 V latching relays were specified, there is no need for an external power supply. The 34945A/L4445A Module can provide power for a single 34945EXT. Easy-to-build ribbon cables can be built to interface each of the switches to the Y1152A Distribution boards.

Example #2

Three separate, but identical, custom-built test boxes have been built and need a switch driver to control switches and attenuators. Each test box already contains the following hardware:

- (2) Agilent 87222E Transfer Switches (24 V)
- (5) Agilent 33314D SPDT Switches (24 V but no position feedback)
- (1) Agilent 84905M 0-60 dB Attenuator (24 V)
- Various filters, power splitters, and amplifiers
- Combination 12 V/24 V power supply to power active devices

The 87222E Transfer switches and the 84905M Attenuators both have latching relays, position feedback, and socket connectors. The 33314D SPDT switches are latching but do not have position feedback. Pulse Mode can be used to drive all devices to the desired state. This results in considerable power savings.

It is desired that the Switch Driver be mounted near or within each test system box. All three test boxes may be active in the test system at once.

Here is a possible Agilent 34980A configuration with discussion points:

- 34980A Switch/Measure Unit
- (1) 34945A Switch/Attenuator Driver w/cable
- (3) 34945EXT with RJ-45 extender cables
- (3) Y1154A Distribution Boards
- (3) Y1155A Distribution Boards
- (3) Y1153A Distribution Boards
- (5) Y1158A Cable Kits for 87222E switches and 84905M attenuators
- Optional (6) Y1159A Cable Kits for LEDs

If using the L4445A Switch/Attenuator, simply replace 34980A, 34945A, and one of the 34945EXT's above with a single L4445A. (It comes with a single 34945EXT).

Using **Tables 1** and **2**, the Agilent 87222E requires the Y1154A Distribution Board. The Agilent 33314D are not supported with connectors so they require the Y1155A Distribution Board. The Agilent 84905M requires the Y1153A Distribution Board.

Since each test box already has a 24 V power supply, that supply will be used to power the 34945EXT modules. The 34945A/L4445A will be connected directly to the first 34945EXT with the supply 9-pin cable. The remaining 34945EXT's are daisy chained from the first 34945EXT using the supplied RJ-45 cables.

If the 24 V power supplies had not been available in the test boxes, the solution could have been to provide three 34945A/L4445A modules where each would be connected to a single 34945EXT. In that case, each 34945EXT would be powered directly by the 34945A/L4445A module. That solution is only possible when all the switches and/or attenuators use 24 V coils.

Additional observations on Examples #1 and #2 configurations:

- Each 34980A has room to expand. You can expand microwave switch control with additional 34945EXTs. Plus there are still 7 slots in the 34980A mainframe for expansion of other modules such as Digital IO, Analog Output, Switching, etc.
- The 34980A has standard LAN, USB, and GPIB for easy connection to a PC. Plus it has a graphical Web interface for controlling the switches over a LAN. The L4445A has optional GPIB, if necessary.
- Example #2 has additional capacity to drive six N181x switches (Y1154A), another attenuator (Y1153A), and six coils not used on the Y1155A.

The 34980EXT is actually designed with mounting holes for locating within test fixtures, as illustrated below. This gets the switches right next to the DUT and improves signal integrity by permitting the use of semi-rigid coax.

The Web Server Diagnostic Tool

The 34980A/L4445A has a built-in Web Server that provides a very powerful configuration, diagnosis, and verification tool. All you need is a LAN connection, Web Browser, and the IP address. If your computer can access eBay.com, you can access a 34980A or L4445A module, from anywhere. You need NO other software to completely configure the 34980A/L4445A. All module drivers exist within the 34980A/L4445A.

The LXI instruments can be configured for DHCP (obtain an IP address from an external host), AutoIP (34980A/L4445A can assign its own IP address), or manual IP assignment. Once you know the IP address, you simply enter that into the Web Browser's URL. Up to six Web Browsers can be simultaneously connected.

The figure at right shows one of the test box configurations.

Here are some of the key capabilities provided in the Web Server:

- Diagnostic tool – troubleshooting and wiring verification
- Visual aid in developing external programs
- Log/capture programming commands (SCPI)
- Learning tool to understand how to program
- Passive monitoring of test system measurements
- Switch relay count report generation
- Create/test switch sequences

The Web Server gives you a graphical representation of each switch module. Switches can be opened and closed by pointing

and clicking your mouse. Other modules, such as Digital IO, Analog Output, etc., are easily and completely configurable from the Web interface.

Having a complete and graphical representation of every switch and module in the 34980A/L4445A is a powerful way to verify wiring and troubleshoot your system configuration. The 34945A/ L4445A Switch Driver module Web Interface makes it easy to setup and verify your discrete RF/Microwave switches and attenuators. The figure below illustrates a partial view of the Web Server when looking at the configuration of the Y1155A distribution board in the previous section, Example #2. Pressing **Open** or **Close** will actuate the switches. If the switch has position feedback, that is reflected under Position Indicator. Note that the example shows a mixture of a Single Channel (single coil drive) and Paired Channel (double coil drive). The single coil drive channel is an addition to Example #2.

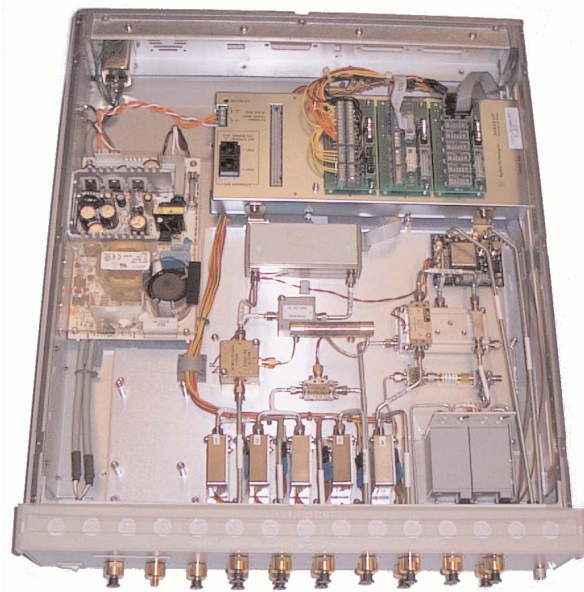

When developing test system programs, you can open up a Web Browser to the 34980A/L4445A, and you can observe switches closing and configurations changing. The Web Server can be set to capture every command/response coming from any interface: Web Browser, USB (34980A only), GPIB, or LAN. The Web Browser is included in this list because it actually sends programming commands (SCPI) to cause changes to the instrument. This helps with understanding the sequence of your test program. That feature is a Learning Aid. Every time you interactively close/open any switch or program any module to any setting with Web Browser, the logging feature

actually shows what SCPI commands were used. You can cut and paste those commands into your test program. You literally don't need a reference manual to understand which commands are needed to set up a particular module!

Once your test system is running, you can passively monitor any channel from up to six Web Browsers. Bringing up a Web Browser to the 34980A/L4445A is always passive when you connect. Unlike some vendors' instruments, the 34980A/L4445A Web Server does not reset or interfere with any configuration when it connects. You have to purposely interfere with modules. You can even configure and work with modules that are not currently being used by the test system program!

Of particular importance in RF/Microwave test systems is creating switch paths and sequences that completely set up different measurements. The 34980A/L4445A provides a Switch Sequencer for that purpose, and that is the topic of the next section.

Switch Executives vs. Agilent 34980A/L4445A Switch Sequencer

When setting up a test system, it is important to make sure that measurement instruments, sources, DUT test points, etc. all switch at the right time and in the right sequence. A matrix switch allows any point to connect to any other point, so it is possible to connect two signal sources together. This must be avoided.

Some measurement setups are fairly complex and require the correct sequence and path through the switching system. Some switches operate quicker than others. Some sources need settling time after being connected to a load. In short, a switch path can include a lot of switches and require a proper sequencing of those switches. That can be a challenge for a programmer.

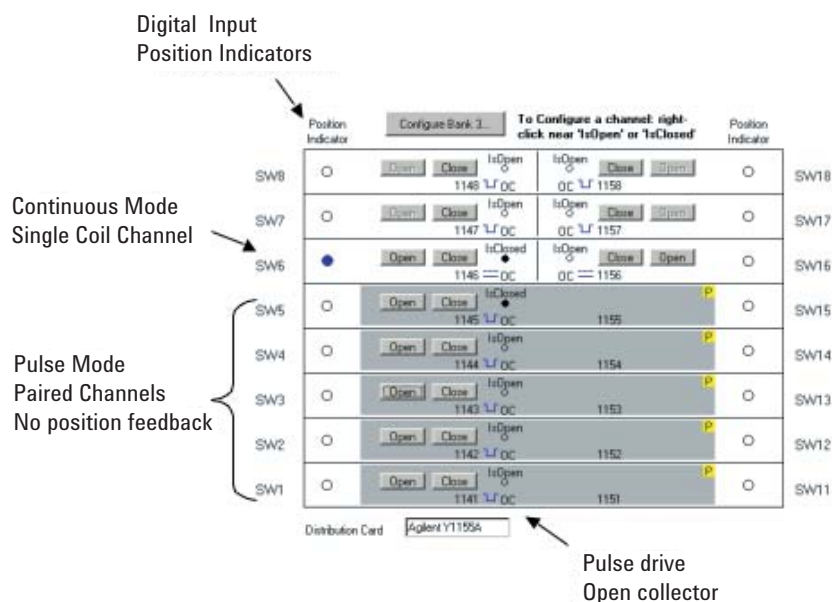

A switch executive is an external software package that provides the following features:

- Switch management and report generation
- Creating switch paths callable from any test program
- Simplify configuration of switching paths
- Mutual exclusion between channels avoids unwanted collisions
- Graphical end-to-end routing between test points
- Typically works through IVI driver supplied by instrument vendor

The 34980A/L4445A provides the critical parts of this functionality related to switching, and it provides features not available in a switch executive: programmable delays between channel closings and control of Analog and Digital Outputs. A clear weakness of a switch executive: it is only as good as the information you program into it. If channels in the system are not wired properly, you won't get proper operation.

The 34980A/L4445A provides ease of verification of wiring through its Web Server, and it can be used to configure and test measurement setups. Those switching setups can be named and called later from any programming environment. You have both visual and total execution control of switching, and you gain execution speed since a sequence of switch closings stored within the 34980A/L4445A is ready to execute from a relatively short ASCII command.

Here is how you might configure a 34980A/L4445A test system:

- Wire instruments and DUT test points via switch modules
- Use the graphical Web Server to verify each channel is connected properly
- Manually close channels to connect instruments to DUT for a measurement
- If necessary, note the need for time delays between channels for settling
- When you have the correct measurement setup, save that as a named sequence
- Repeat that operation until you have all setups created and named
- Call the named sequences from your test program

A good example use of the sequencer is assigning a sequence to select an attenuator path. Attenuators typically have 3 to 4 sections to include or exclude different degrees of attenuation. This means you would have to issue up to 4 open or close commands to select a particular attenuation setting. The name "ATTENUATOR_60DB" could be assigned to a sequence of opens and closes that will select the proper attenuation. You don't have to remember which channels to open or close! Here's what the SCPI command would look like:

```
":ROUT:SEQ:TRIG ATTENUATOR_60DB"
```

As a test engineer, there are few around that know the system better than you. If you manually verify and configure the measurement switch sequences, there is no need to worry about outputs colliding. Mutual exclusion is guaranteed by your expertise! The programmer's job becomes simpler, and the speed of the system is enhanced when using sequences.

Conclusion

You have been introduced to a number of 34980A/L4445A capabilities related to RF/Microwave switching. You have gained a better understanding of how an RF/Microwave test system might be built using the 34945A/L4445A Switch Driver to control discrete switches and attenuators. Let's review some key learning's from this application note:

- Test systems can use mainframe switch modules or discrete switching
- Discrete switches and attenuators give you more control of signal integrity
- The 34945A/L4445A Switch Driver directly supports Agilent's most popular switches
- Configuration tables make it easy to configure Agilent switches to the 34980A/L4445A
- The 34945A/L4445A can also control just about any other discrete switch or attenuator
- Wiring, verification, and troubleshooting are simplified with the the built-in Web Server
- The 34980A/L4445A built-in Sequencer performs most switch executive functions

Glossary

DUT – Device Under Test

IVI – Interchangeable Virtual Instruments. See <http://www.ivifoundation.org> for more information

LAN – 34980A Supports 10/100 Mbit Ethernet

LXI - LAN eXtensions for Instrumentation. See <http://www.lxistandard.org> for more information

SCPI – Standard Commands for Programmable Instrumentation. This is an English-style language that has been used in instrumentation for many years.

VSWR – Voltage Standing Wave Ratio

Web Server – Software that runs inside the 34980A/L4445A that “serves up” Web pages to a browser at the specified IP address

Related Agilent literature

Data sheets

Agilent 34980A Multifunction Switch/Measure Unit
5989-1437EN

Application notes

Test System Signal Switching, AN 1441-1
5988-8627EN
<http://cp.literature.agilent.com/litweb/pdf/5988-8627EN.pdf>

Test-System Development Guide: Introduction to Test-System Design, AN 1465-1
5988-9747EN
<http://cp.literature.agilent.com/litweb/pdf/5988-9747EN.pdf>

Benefits of a Switch/Measure Unit for Data Acquisition and Electronic Functional Test
5989-1481EN
<http://cp.literature.agilent.com/litweb/pdf/5989-1481EN.pdf>

34980A Multifunction Switch/Measure System Modules Applications that benefit from specific module features/functions
5989-2371EN
<http://cp.literature.agilent.com/litweb/pdf/5989-2371EN.pdf>

Agilent L4445A Microwave/Attenuator Switch Driver
5989-4828EN

Books

Test System Design, Authors: Christie Tursky, Rodney Gordon, Scott Cowie Available through most bookstores ISBN 0-13-027260-4 and Prentice Hall.

For additional information please visit:
<http://www.agilent.com/find/L4445A>
<http://www.agilent.com/find/34980A>



Agilent Email Updates

www.agilent.com/find/emailupdates
Get the latest information on the products and applications you select.



Agilent Direct

www.agilent.com/find/agilentdirect
Quickly choose and use your test equipment solutions with confidence.



Agilent Open

www.agilent.com/find/open
Agilent Open simplifies the process of connecting and programming test systems to help engineers design, validate and manufacture electronic products. Agilent offers open connectivity for a broad range of system-ready instruments, open industry software, PC-standard I/O and global support, which are combined to more easily integrate test system development.



LXI

www.lxistandard.org
LXI is the LAN-based successor to GPIB, providing faster, more efficient connectivity. Agilent is a founding member of the LXI consortium.

Remove all doubt

Our repair and calibration services will get your equipment back to you, performing like new, when promised. You will get full value out of your Agilent equipment throughout its lifetime. Your equipment will be serviced by Agilent-trained technicians using the latest factory calibration procedures, automated repair diagnostics and genuine parts. You will always have the utmost confidence in your measurements.

Agilent offers a wide range of additional expert test and measurement services for your equipment, including initial start-up assistance onsite education and training, as well as design, system integration, and project management.

For more information on repair and calibration services, go to:

www.agilent.com/find/removealldoubt

www.agilent.com

For more information on Agilent Technologies' products, applications or services, please contact your local Agilent office. The complete list is available at:

www.agilent.com/find/contactus

Americas

Canada	(877) 894-4414
Latin America	305 269 7500
United States	(800) 829-4444

Asia Pacific

Australia	1 800 629 485
China	800 810 0189
Hong Kong	800 938 693
India	1 800 112 929
Japan	81 426 56 7832
Korea	080 769 0800
Malaysia	1 800 888 848
Singapore	1 800 375 8100
Taiwan	0800 047 866
Thailand	1 800 226 008

Europe

Austria	0820 87 44 11
Belgium	32 (0) 2 404 93 40
Denmark	45 70 13 15 15
Finland	358 (0) 10 855 2100
France	0825 010 700
Germany	01805 24 6333*
	*0.14 €/minute
Ireland	1890 924 204
Italy	39 02 92 60 8484
Netherlands	31 (0) 20 547 2111
Spain	34 (91) 631 3300
Sweden	0200-88 22 55
Switzerland (French)	41 (21) 8113811(Opt 2)
Switzerland (German)	0800 80 53 53 (Opt 1)
United Kingdom	44 (0) 118 9276201

Other European Countries:

www.agilent.com/find/contactus

Revised: May 7, 2007

Product specifications and descriptions in this document subject to change without notice.

© Agilent Technologies, Inc. 2007
Printed in USA, July 13, 2007
5989-2272EN



Agilent Technologies